

CEDAR FALLS COMMUNITY SCHOOL DISTRICT



2021 Summer Roof and Masonry Projects

Locations

- Summer 2021 roof replacement project:
 - Orchard Hill Elementary School
 - SW Classroom (Original Building) Level D
- Summer 2021 masonry repair projects:
 - Southdale Elementary School
 - Various Sections
 - Central Administration

Orchard Hill Roof Project Detail

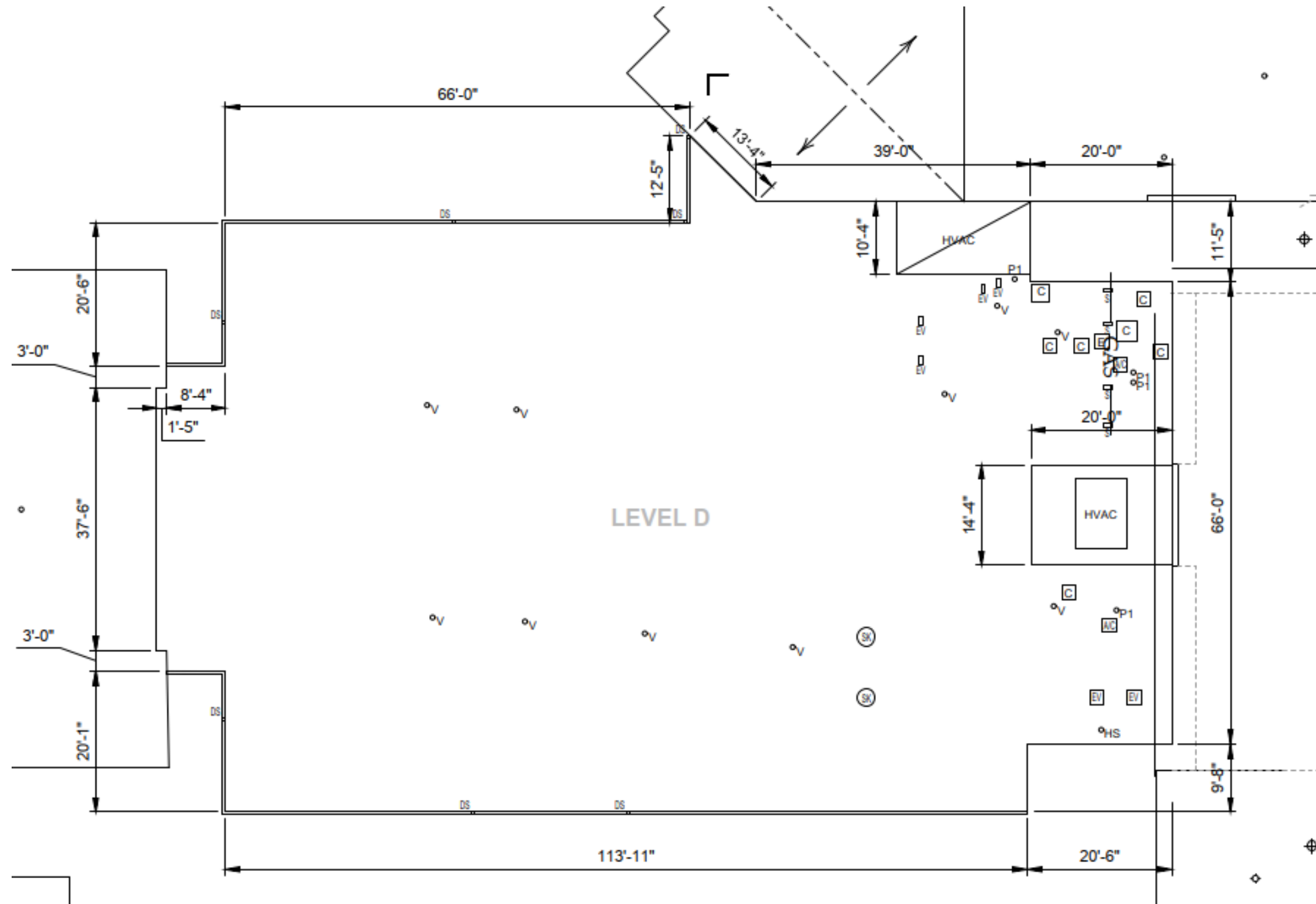

Square footage - 12,900

North

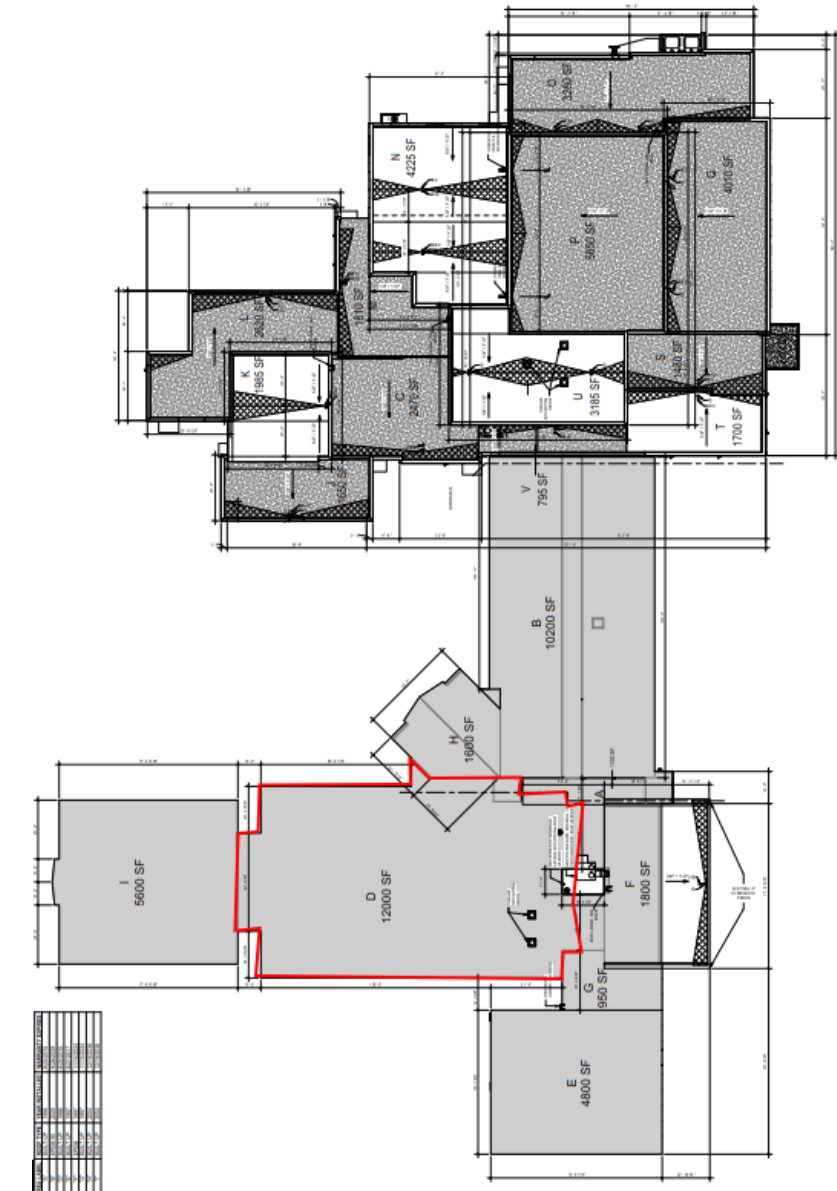

Southdale Masonry Repairs Project Detail

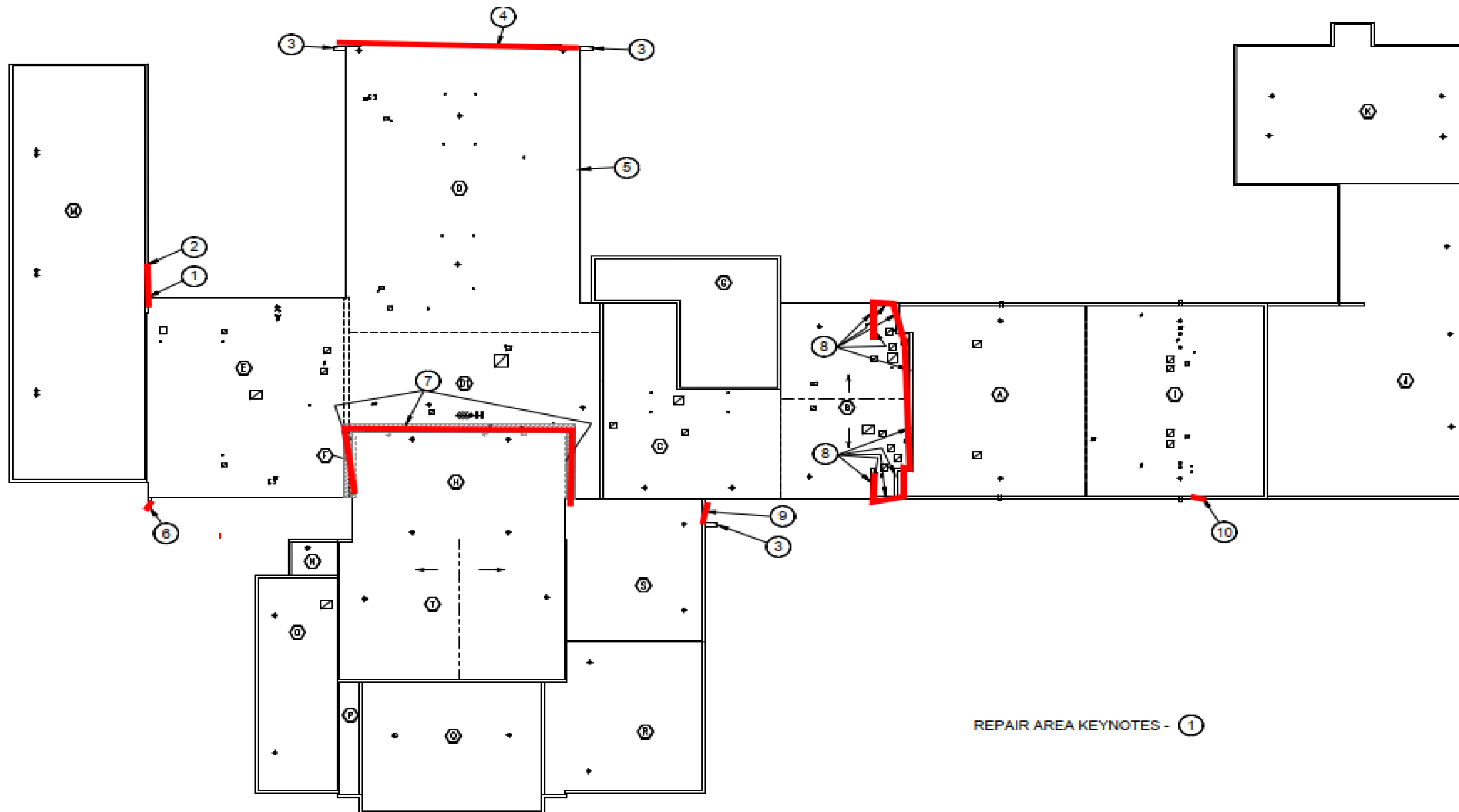

↑
North

REPAIR AREA KEYNOTES - ①



Central Administration Masonry Repair Project Detail

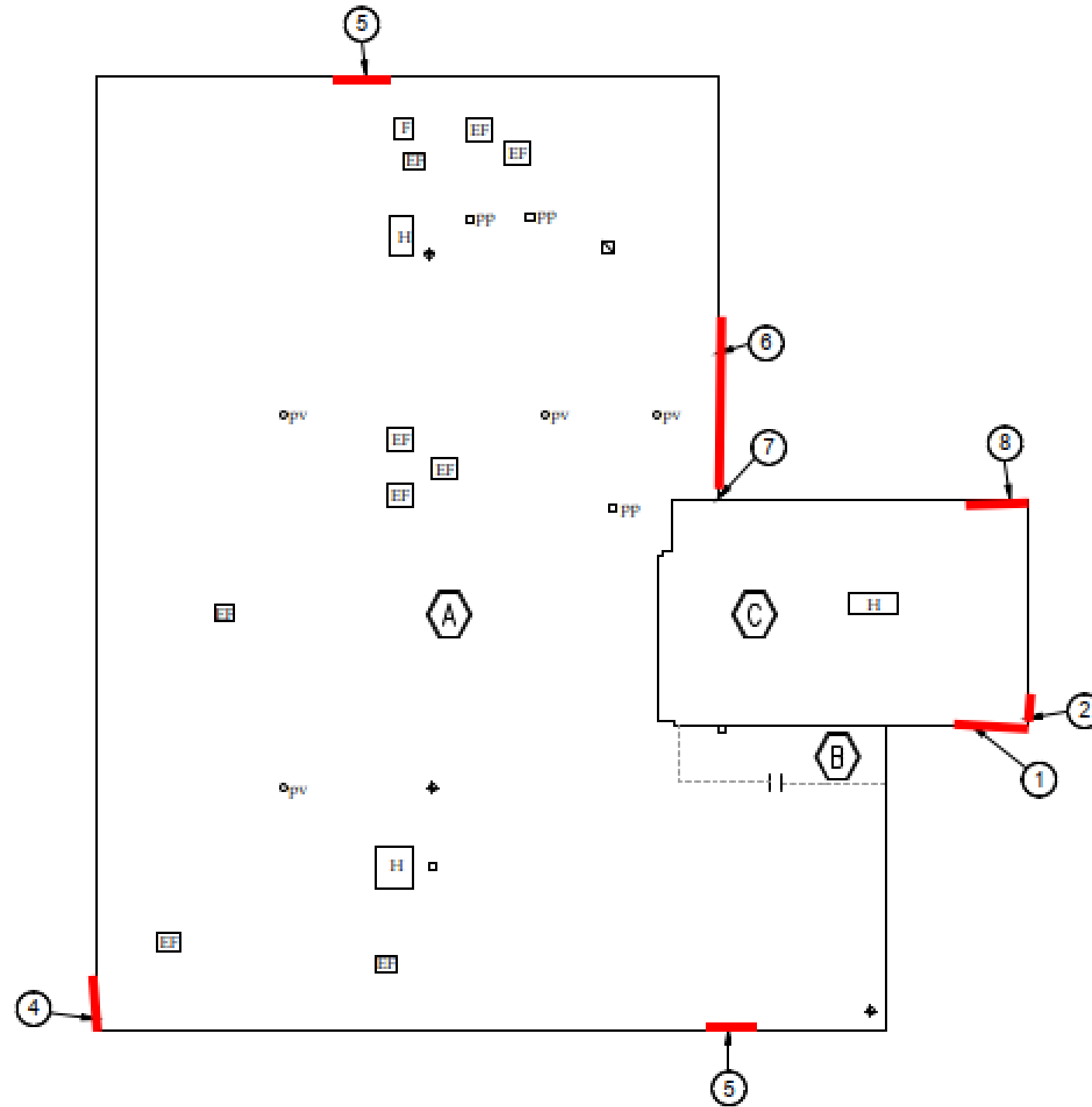

CEDAR FALLS CENTRAL ADMINISTRATION
MASONRY REPAIR PLAN
SCALE: 1" = 40' (PLOTTED on 11"x17" PAPER)

Budget

- Dollars allocated within 10 yr. PPEL plan (30 year warranty for roof)

Construction Cost Estimate

<u>Location</u>	<u>Sec.</u>	<u>Sq. Ft.</u>	<u>Total Cost</u>
Orchard Hill Elem Roof	D	12,654	\$227,772
Southdale Masonry Repairs (2012 report)			\$100,690
Central Admin. Masonry Repairs (2012 report)			\$635
Total			\$327,097

Anticipated Construction Costs

- **Orchard Hill Level D Roof** **\$179,500**
- **Roof repairs –various buildings** **\$15,515**
- **Southdale Elem Masonry Repairs** **\$80,730**
- **Central Admin. Masonry Repairs** **\$ 6,030**
- **TOTAL** **\$281,775**

Timeline

- January 11, 2021 – Presentation to Board of Education
- January 25, 2021 – Public Hearing
- February 2, 2021 – Bid Opening
- February 8, 2021 – Award Contract
- Week of June 14, 2021 – Begin Construction
- August 6, 2021 – Construction Complete

Questions?